

### Characteristics:

1. Vacuum epoxy resin encapsulated, 100°C /6 hours high temperature aging, long working life 20 years and with high dielectric strength
2. High quality H18 laminated silicon steel, low temperature rise, high efficiency
3. PBT engineering plastic, environmental protection, flame retardant, 120 degrees no deformation
4. Reasonable structure, convenient installation, low noise, strong seismic, sealed waterproof, moisture-proof

Product picture print for reference only, subject to the actual product

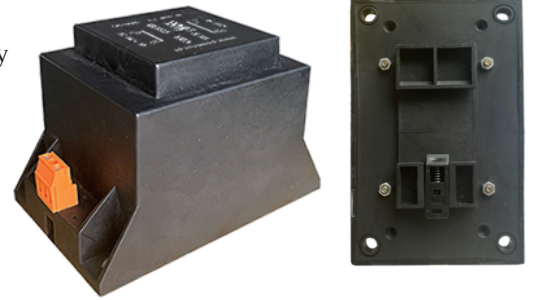

### Technical index:

Mounting type: Din-rail mounting

Flame resistance : UL94-V0

Insulation class: B

Operation temperature: -30°C ~ +40°C

Work frequency: 50Hz ~ 60Hz

Dielectric strength: Pri/Sec. 3.5KV 50Hz 1min 5mA,  
Sec/Sec 500V 50Hz 1min 5mA

### Standard output parameter table:

( Factory test is based on the full-load voltage )

Secondary output voltage		Secondary no-load voltage		Secondary full-load current	
Single	Double	Single	Double	Single	Double
9V	2×9V	9.7V	2×9.7V	13.33A	2×6.67A
12V	2×12V	12.9V	2×12.9V	10A	2×5A
15V	2×15V	16.2V	2×16.2V	8A	2×4A
18V	2×18V	19.4V	2×19.4V	6.66A	2×3.33A
24V	2×24V	25.9V	2×25.9V	5A	2×2.5A

Electrical parameters: ( The following parameters are typical values and actual values will be subject to product testing )

Primary voltage	110V	220V	230V	380V	Unit
Primary voltage range	± 10				%
Power	120				VA
Voltage regulation	≤ 8				%
Temperature rising	≤ 40				°C
No-load loss	≤ 3.5				W
Weight	2.2				Kg

### Schematic diagram:

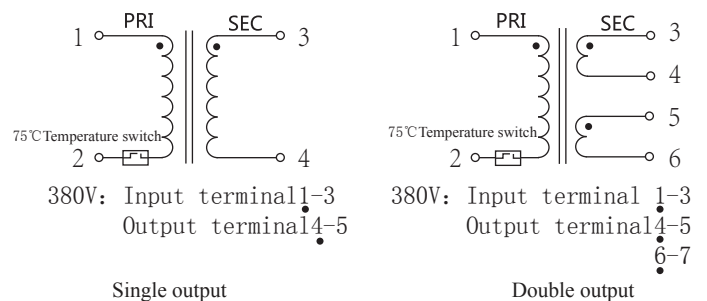

### Dimensions (in mm±0.5)

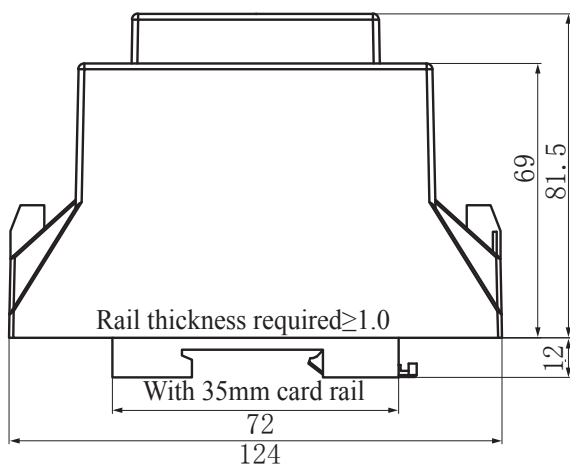

Front view

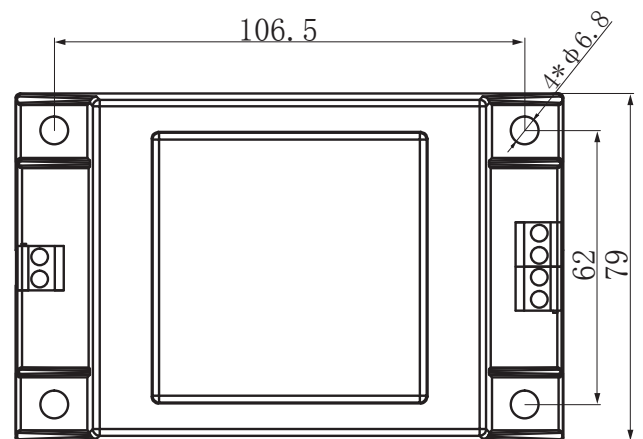

Top view

# Package

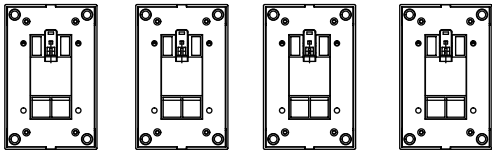

4 pieces/plate

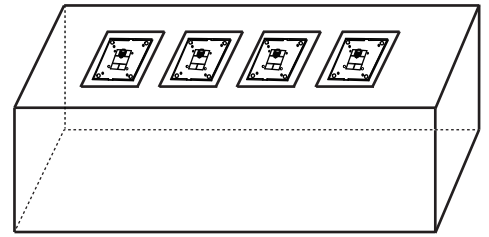

Place the product bottom side up into the pearl cotton groove

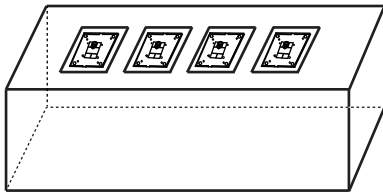
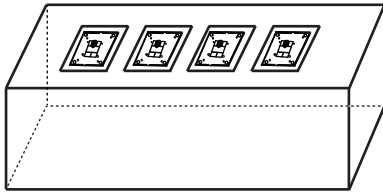

2 disks/box

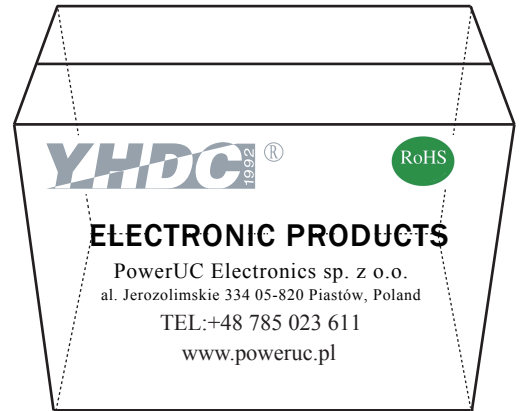
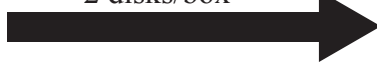

Box 2 trays of pearl cotton

44 boxes/pallet

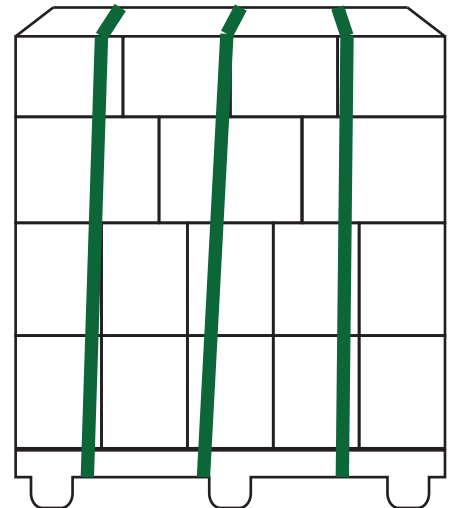

Load 44 boxes into trays

Package	Each	Approx. 2.2Kg	1PCS
	Per disc	Approx. 8.9Kg	4PCS
	Each box	Approx. 18.3Kg	8PCS
	Per torr	Approx. 818Kg	352PCS

Note: The above packaging (large volume) is for reference only, the actual packaging is subject to production and delivery.