

Characteristics:

1. Vacuum epoxy resin encapsulated, 100°C /6 hours high temperature aging, long working life 20 years and with high dielectric strength
2. High quality H18 laminated silicon steel, low temperature rise, high efficiency
3. PBT engineering plastic, environmental protection, flame retardant, 120 degrees no deformation
4. Reasonable structure, convenient installation, low noise, strong seismic, sealed waterproof, moisture-proof

Technical index:

Mounting type: Din-rail mounting

Flame resistance : UL94-V0

Insulation class: B

Operation temperature: -30°C ~ +40°C

Work frequency: 50Hz ~ 60Hz

Dielectric strength: Pri/Sec. 3.5KV 50Hz 1min 5mA,
Sec/Sec 500V 50Hz 1min 5mA

Electrical parameters: (The following parameters are typical values and actual values will be subject to product testing)

Primary voltage	110V	220V	230V	380V	Unit
Primary voltage range	± 10				%
Power	60				VA
Voltage regulation	≤ 12				%
Temperature rising	≤ 28				°C
No-load loss	≤ 2.5				W
Weight	1194				g

Dimensions (in mm±0.5)

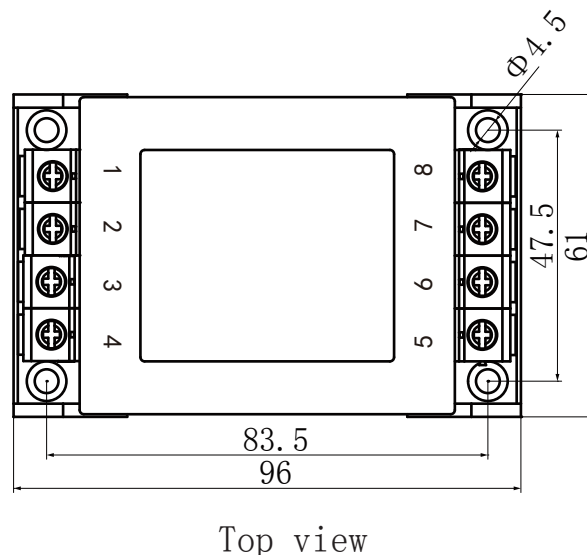
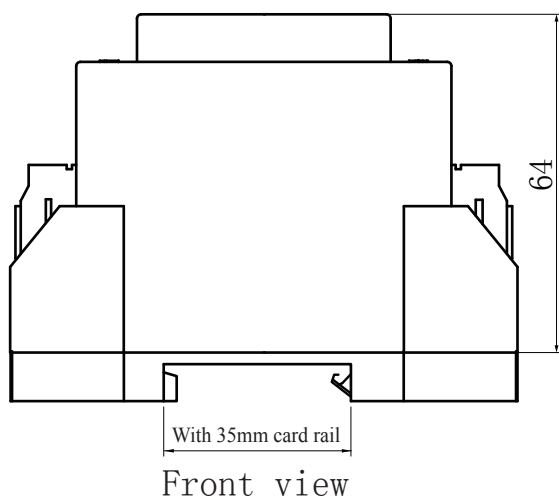

Product picture print for reference only, subject to the actual product

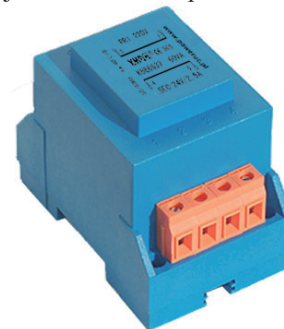

Standard output parameter table:

(Factory test is based on the full-load voltage)

Secondary output voltage		Secondary No-load Voltage		Secondary full-load current	
Single	Double	Single	Double	Single	Double
6V	6V × 2	6.7V	6.7V × 2	10A	5A × 2
7.5V	7.5V × 2	8.4V	8.4V × 2	8A	4A × 2
9V	9V × 2	10.2V	10.2V × 2	6.66A	3.33A × 2
12V	12V × 2	13.5V	13.5V × 2	5A	2.5A × 2
15V	15V × 2	16.9V	16.9V × 2	4A	2A × 2
18V	18V × 2	20.3V	20.3V × 2	3.33A	1.665A × 2
24V	24V × 2	27.1V	27.1V × 2	2.5A	1.25A × 2

Schematic diagram:

