

Patent number: ZL 2020 2 1000365.1

**Characteristics:**

1. Vacuum epoxy resin encapsulated, 100 °C /6 hours high temperature aging, long working life 20 years and with high delectric strength
2. High quality H18 laminated silicon steel, low temperature, high efficiency
3. PBT engineering plastic, environmental protection, flame retardant, 120 degrees without deformation
4. Reasonable structure, easy installation, low noise, strong earthquake sealed waterproof, moistureproof

**Technical index:**

Mounting type: Plate

Flame resistance : UL94-V0

Insulation class: B

Operation temperature: -30 °C ~+70 °C

Work frequency: 50Hz~60Hz

Dielectric strength: Pri/Sec 3.75KV 50Hz 1min 5mA  
Sec 500V 50Hz 1min 5mA

Electrical parameters: The following parameters are typical values. The actual values shall be subject to the actual measurement of the product

Primary voltage	110V	220V	230V	380V	Unit
Primary voltage range	± 10				%
Power	1.9				VA
Voltage regulation	≤ 32				%
Temperature rising	≤ 15				°C
No-load loss	≤ 0.4				W
Weight	105				g

**Dimensions (in mm±0.5)**

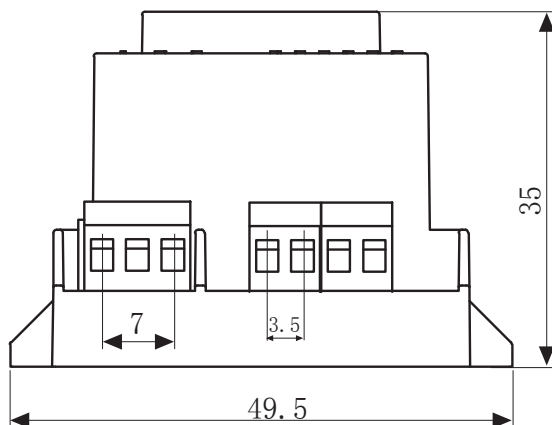

Front view

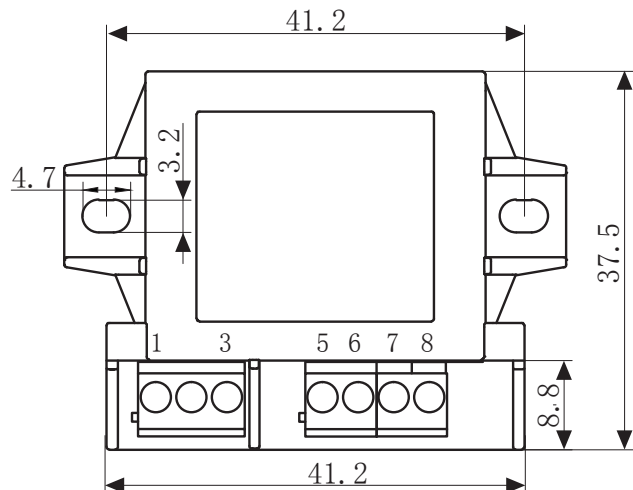

Top view

Product picture print for reference only, subject to the actual product



**Standard output parameter table:**

( Factory test is based on the full-load vottage )

Secondary output voltage		Secondary No-load Voltage		Secondary full -load current	
Single	Double	Single	Double	Single	Double
6V	2 × 6V	8V	2 × 8V	317mA	2 × 158mA
7.5V	2 × 7.5V	10.5V	2 × 10.5V	253mA	2 × 127mA
9V	2 × 9V	12.5V	2 × 12.5V	211mA	2 × 106mA
12V	2 × 12V	16.5V	2 × 16.5V	158mA	2 × 79mA
15V	2 × 15V	21.5V	2 × 21.5V	127mA	2 × 63mA
18V	2 × 18V	26V	2 × 26V	106mA	2 × 53mA
24V	2 × 24V	33V	2 × 33V	79mA	2 × 40mA

**Schematic diagram:**

