

## Introduction

ZDA13A is a type-B residual current monitoring device that is specifically designed for EV charging applications. It fully complies with the IEC62752 and IEC62955 standards. This sensor offers comprehensive all-current sensitivity, ensuring optimal safety during the charging process.

Product picture print for reference only, subject to the actual product

## Product features

- Value optimized
- Built-in test and calibrate function
- Built-in three-phase conductors
- Operating supply voltage range: 4.8V – 5.2V
- Wide operating temperature range: -40°C ~ +85°C
- High insulation voltage
- Small size
- Low power consumption

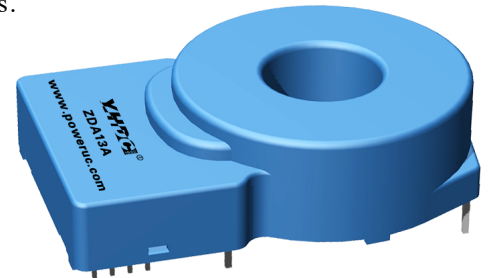

## Applications

- AC wallboxes
- ICCPD (charging cable)

## Operating Conditions:

Aperture size	φ13.5
Ambient Operation Temperature Range	-40 °C - 85 °C
Power Supply Voltage	Min.: 4.8V Typ.: 5V Max.: 5.2V
Input Pin Voltage Range	Min.: -0.3V Max.: 5.5V
Input Pin Low-Level Voltage	Max.: 0.8V
Input Pin High Level coltage	Min.: 2.5V
Supply Current	Typ.: 16mA

## Specifications:

Type	DC6mA / AC20mA	DC6mA / AC30mA
DC Trip Threshold	Min.: 3.5mA Typ.: 4.5mA Max.: 5.5mA	Min.: 3.5mA Typ.: 4.5mA Max.: 5.5mA
AC Trip Threshold	Min: 12.5mA Typ.: 15mA Max: 17.5mA	Min: 18mA Typ.: 22.5mA Max: 27mA
DC Recovery Level	3mA	3mA
AC Recovery Level	10mA	15mA

**Specifications:**

Frequency Range	DC ~ 2kHz	DC ~ 2kHz
PWMOUT vs DC differential current ratio	3.33%/mA	3.33%/mA
Response Times	Compliant with IEC62752:2016	Compliant with IEC62752:2016
Weight	20g	20g

**Pin descriptions:**

Pin	Description
Pin1 – ERROR	When the device is operating normally, this pin stays low. If an error is detected, the pin becomes high.
Pin 2 – TEST	<p>Input pin for signal to start the calibration and test function. This procedure is automatically executed at start-up.</p> <p>During the test function, the system's tripping threshold is calibrated, then a test current is applied. The device then should trip within the response time limits, indicating that it is functioning normally.</p> <p>During the test function, the charging must not be ongoing to ensure that there is no differential current present, other than the test currents applied by the device itself.</p> <p>This function should be activated whenever possible (e.g. before initiating charging or whenever charging is not ongoing) to ensure good accuracy.</p>
Pin 3 – DCTRIP	Output pin for signal indicating a DC trip. When the measured DC differential current value is under the threshold values, the pin stays at low. Otherwise, the pin is set to high.
Pin 4 - ACTRIP	Output pin for signal indicating AC trip. When the measured AC differential current value is under the threshold value, the pin stays at low. Otherwise, the pin is set to high.
Pin 5 - GND	Ground
Pin 6 - VDD	Power Supply
Pin 7 - PWMOUT	PWM output signal with $f = 8\text{kHz}$ , representing the DC differential current level. This signal shall only be used for monitoring purposes.
Pin 8 – N.C.	-

Typical application diagram:

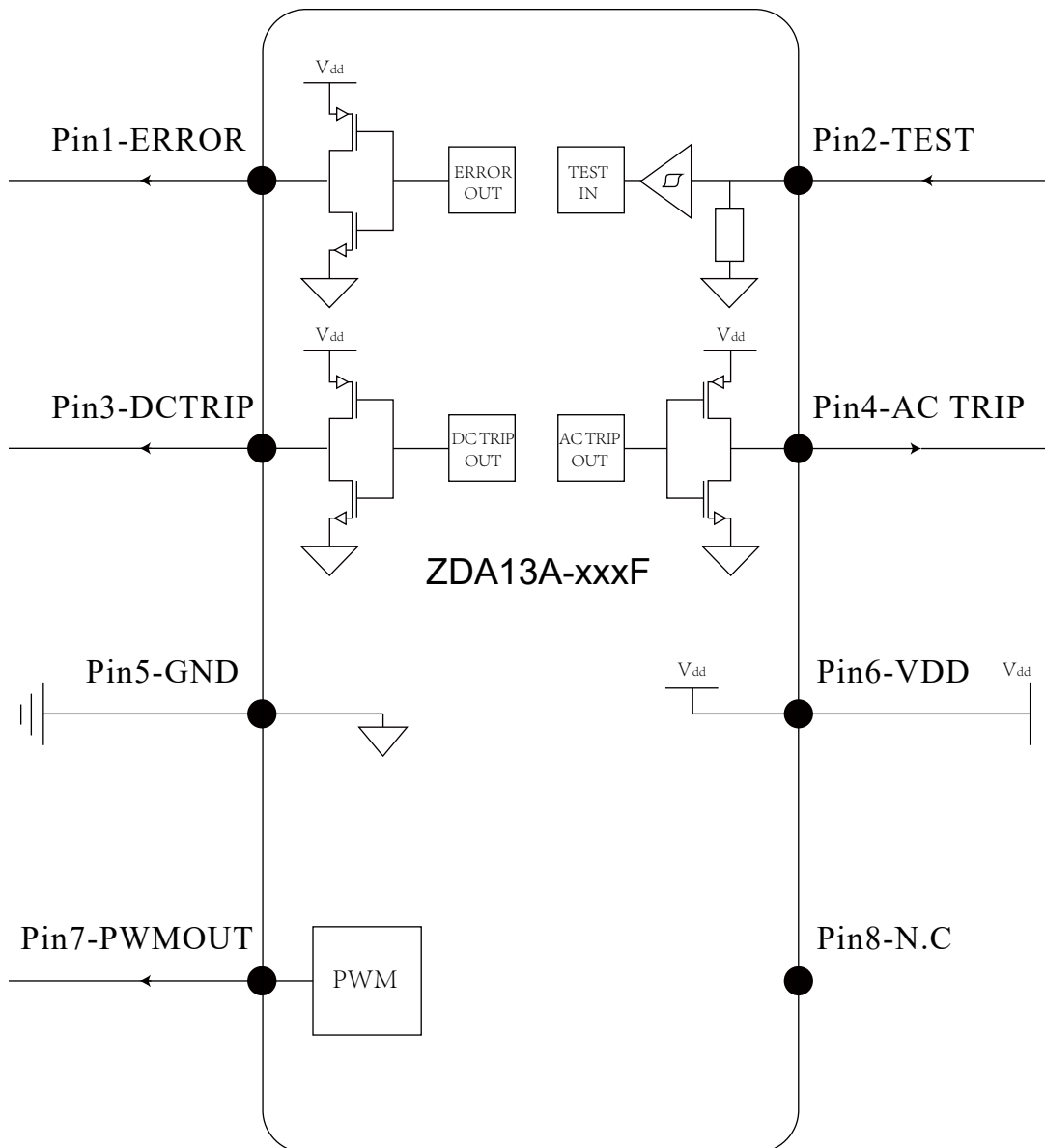
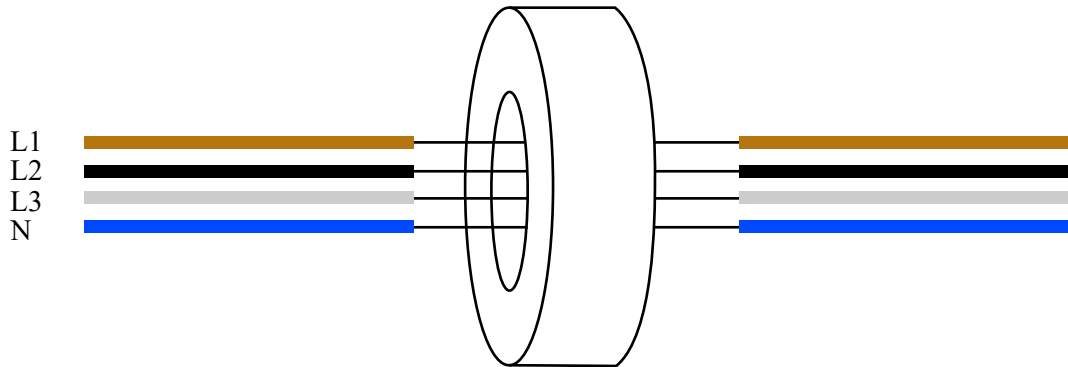

**Dimensions: (in:mm±0.5)**

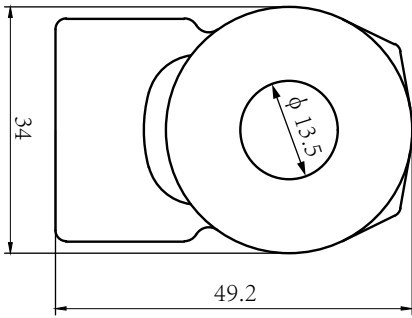

Top view

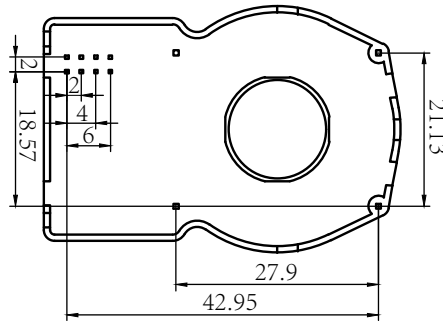

Bottom view

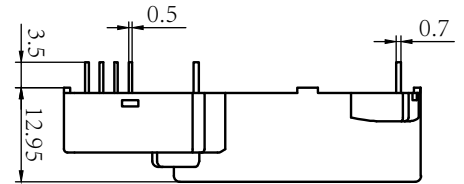

Side view

**Timing graph:**

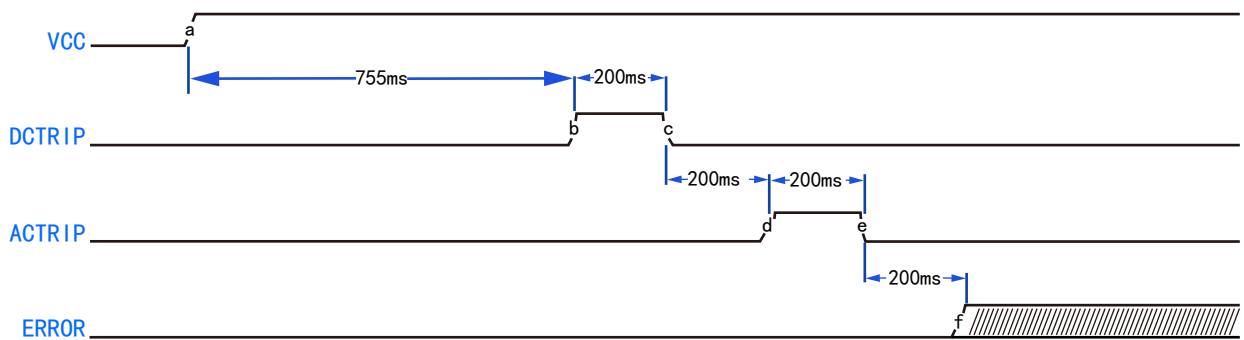

a:	VCC is supplied
b:	DCTRIP becomes high, indicating that DC test has passed
c:	DCTRIP becomes low
d:	ACTRIP becomes high, indicating that AC test has passed
e:	ACTRIP becomes low
f:	*IF* either AC or DC test has failed, ERROR becomes high