

Detect DC, AC and pulse current, high insulation between primary side and the vice side circuit.

Product picture printing is for reference only, subject to the actual product

### Product application

- Metallurgy
- Welding machine
- Robot
- Inverter power
- Inverter speed controller
- UPS uninterruptible power supply

### Product features

- Light weight
- Low power consumption
- Beautiful appearance
- Fast response time
- No insertion loss
- Sub-plate mounting and easy to use



Electrical parameters: the following parameters are typical values, the actual values shall be subject to the actual measurement of the product

Rated input	±500A	±800A	±1000A	±1200A	±1500A	±2000A
Input measurement range	±600A	±960A	±1200A	±1440A	±1800A	±2400A
Rated output	2.5V±0.625V					
Rated input	±1500A	±1600A	±1700A	±1800A	±1900A	±2000A
Input measurement range	±1500A	±1600A	±1700A	±1800A	±1900A	±2000A
Rated output	2.5V±2V					
Accuracy	1%					
Linearity	1%					
Supply voltage	+5V±5%					
Current consumption	≤16mA					
Load impedance	≥10KΩ					
Zero offset voltage	≤±15mV					
Response time	≤5μs					
Weight	542g					
Operation temperature	-10℃~+70℃					
Storage temperature	-25℃~+70℃					
Band width	DC~10KHz					
Dielectric strength	3KV 50Hz 1min					

Calculation formula:  $2.5V \pm 0.625V$  (or  $\pm 2V$ )

Forward direction:  $2.5 + (I/I_{PN}) * 0.625$  (or  $\pm 2$ )

Reverse direction:  $2.5 - (I/I_{PN}) * 0.625$  (or  $\pm 2$ )

I: Actual measured current

$I_{PN}$ : Rated input current

### Wiring diagram:

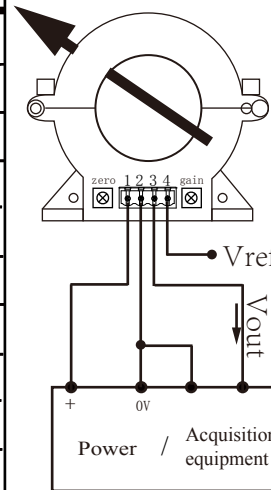

### Terminal definition:

- 1: V+
- 2: 0V
- 3: Vout
- 4: Vref

### Connector:

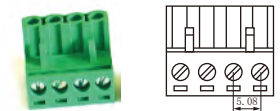

Crimping terminal fast plug  
2EDG-5.08-4p spacing 5.08mm

### Factory commissioning:

1. Debug with 0V as the reference point (acquiescence)
2. Debug with Vref as the reference point (optional)

### Dimensions (in mm±0.5):

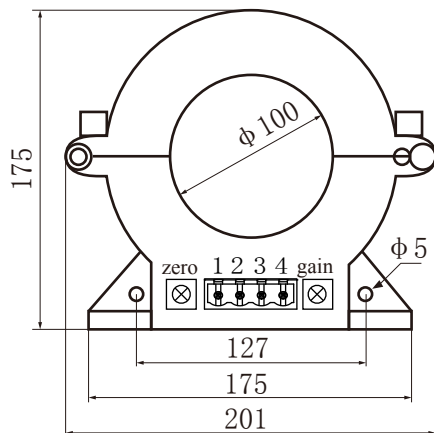

Front view

Current direction  
Print surface ← Epoxy surface

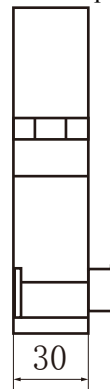

Side view

Fixed hole

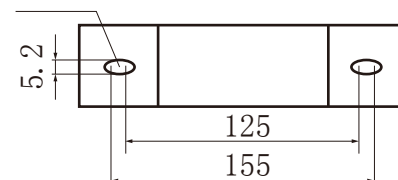

Bottom view